

Schroders RF Limited

Completed transactions

June 2021



Recent Transaction – Botany, NSW

| | |
|-------------------------|--|
| Loan Purpose | Assist with purchase of new factory unit |
| Loan Amount | \$4,000,000 |
| Loan Term | 12 Months |
| Interest Cover | 6 months interest capitalised within Loan Amount |
| Loan to Valuation Ratio | 55.0% |
| Security | First Registered Mortgage Director Guarantee General Security Agreement – Borrower General Security Agreement - Guarantor |



Recent Transaction – Coogee and Potts Point, NSW

| | |
|-------------------------|---|
| Loan Purpose | Assist with purchase of additional investment property |
| Loan Amount | \$2,000,000 |
| Loan Term | 12 Months |
| Interest Cover | Interest capitalised within Loan Amount |
| Loan to Valuation Ratio | 55.0% |
| Security | First Registered Mortgage Director Guarantee General Security Agreement |



Recent Transaction – Riverstone, NSW

| | |
|-------------------------|--|
| Loan Purpose | 62 Lot residential subdivision |
| Loan Amount | \$15,200,000 |
| Loan Term | 13 Months |
| Interest Cover | Interest capitalised within Loan Amount |
| Loan to Valuation Ratio | Loan to Development Cost Ratio 75.0% Loan to Value Ratio 'as is' and on completion 48.0% |
| Security | First Registered Mortgage Director Guarantee General Security Agreement Tri partite Deed with Builder |

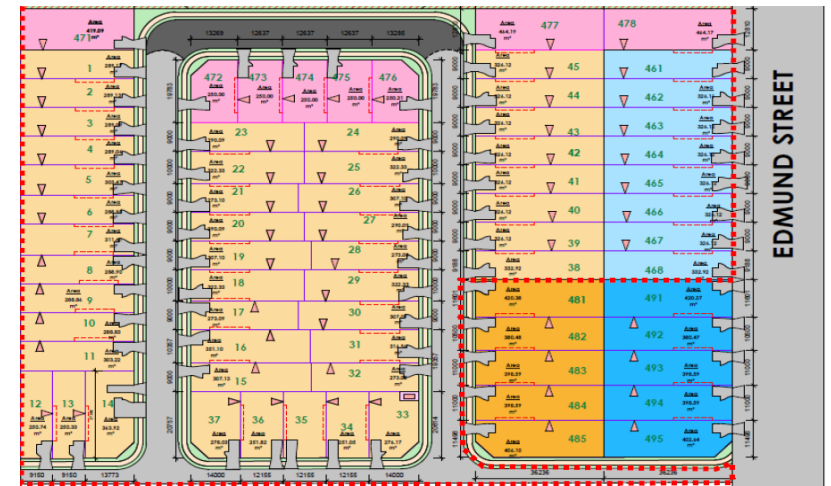
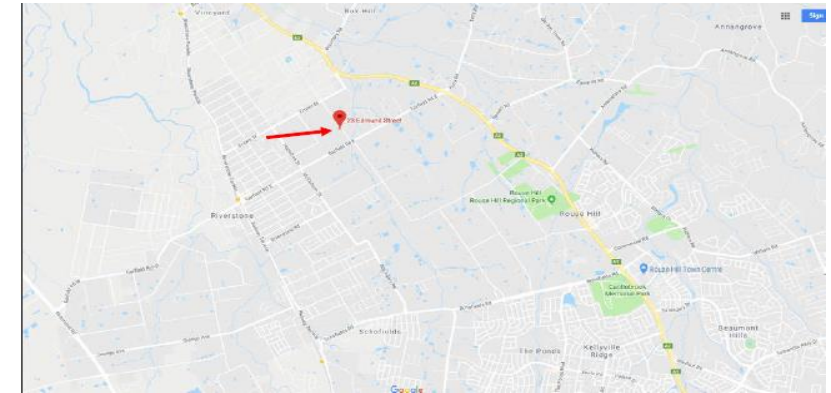

Recent Transaction – Smithfield, NSW

| | |
|-------------------------|--|
| Loan Purpose | Refinance existing loan over industrial premises, leased to single tenant |
| Loan Amount | \$5,295,000 |
| Loan Term | 18 Months |
| Interest Cover | 6 months interest capitalised within Loan Amount |
| Loan to Valuation Ratio | 65.0% |
| Security | First Registered Mortgage Director Guarantee General Security Agreement – Borrower General Security Agreement - Guarantor |

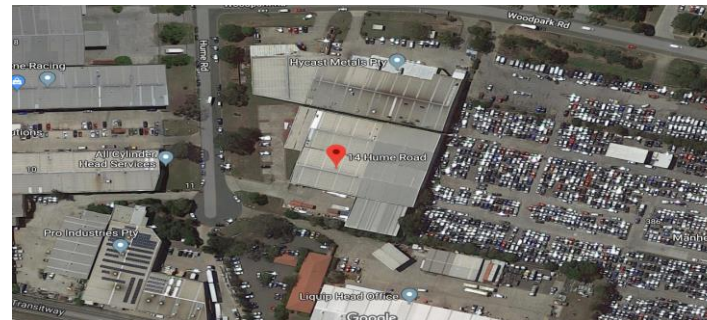
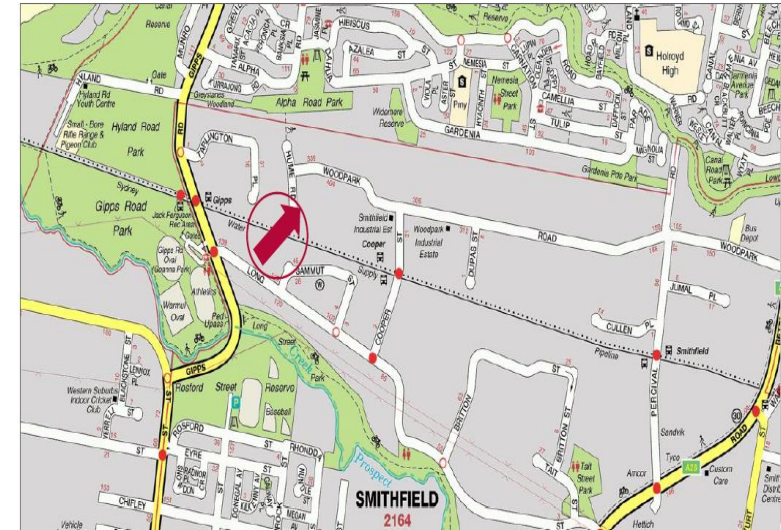

Recent Transaction – Smithfield, NSW

| | |
|-------------------------|--|
| Loan Purpose | Refinance industrial property from existing lender, Multi Tenanted- Office and Industrial Components |
| Loan Amount | \$10,725,000 |
| Loan Term | 18 Months |
| Interest Cover | 6 months interest capitalised within Loan Amount |
| Loan to Valuation Ratio | 65.0%. |
| Security | First Registered Mortgage Director Guarantee General Security Agreement – Borrower General Security Agreement - Guarantor |

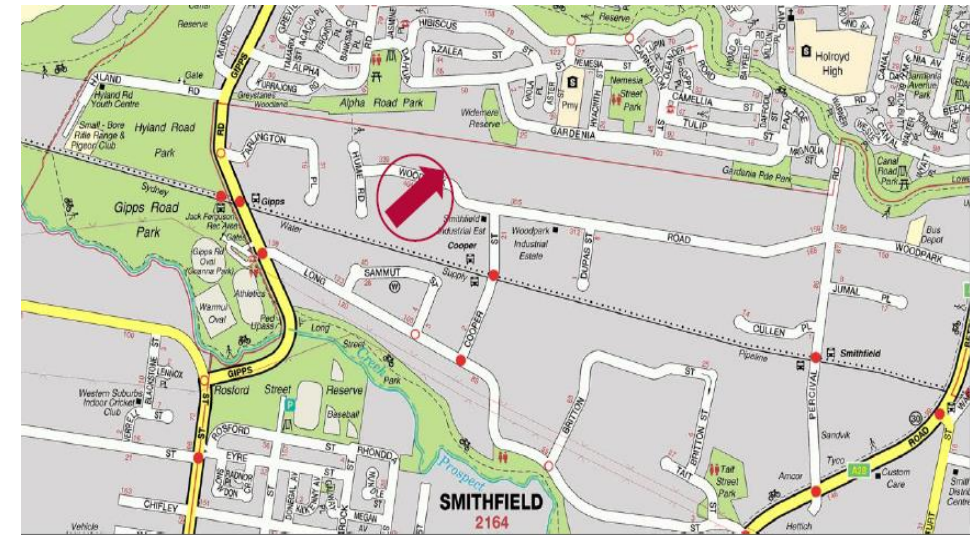

Recent Transaction – Rockdale, NSW

| | |
|-------------------------|---|
| Loan Purpose | Assist with completion of purchase of Development site- Former RSL Club Premises with DA. |
| Loan Amount | \$5,775,000 |
| Loan Term | 12 Months |
| Interest Cover | Interest capitalised within Loan Amount |
| Loan to Valuation Ratio | 50.0% |
| Security | First Registered Mortgage Director Guarantee General Security Agreement |

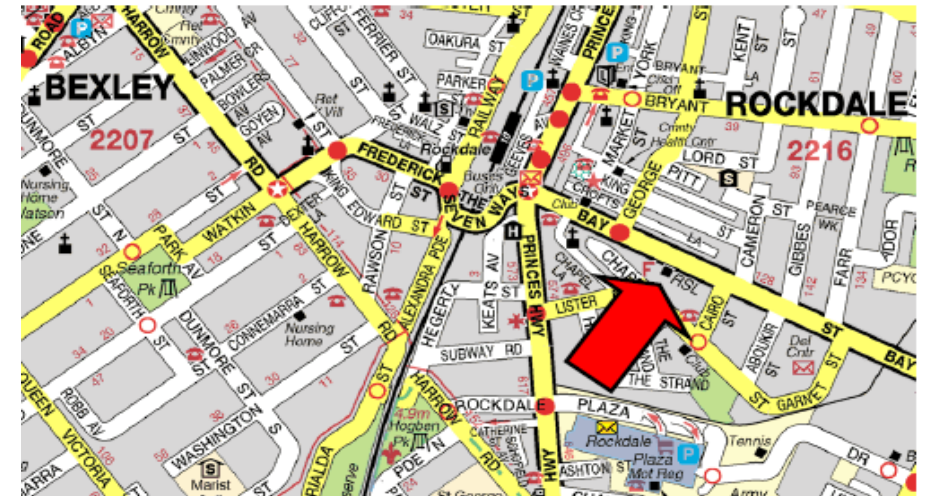

Recent Transaction – Ashfield, NSW

| | |
|-------------------------|--|
| Loan Purpose | Assist purchase of future development site, short term lease back to NSW Govt. |
| Loan Amount | \$6,600,000 |
| Loan Term | 12 Months |
| Interest Cover | 1.38 time stand alone and 1.58 times all sources |
| Loan to Valuation Ratio | 60.0% |
| Security | First Registered Mortgage Director Guarantee General Security Agreement |

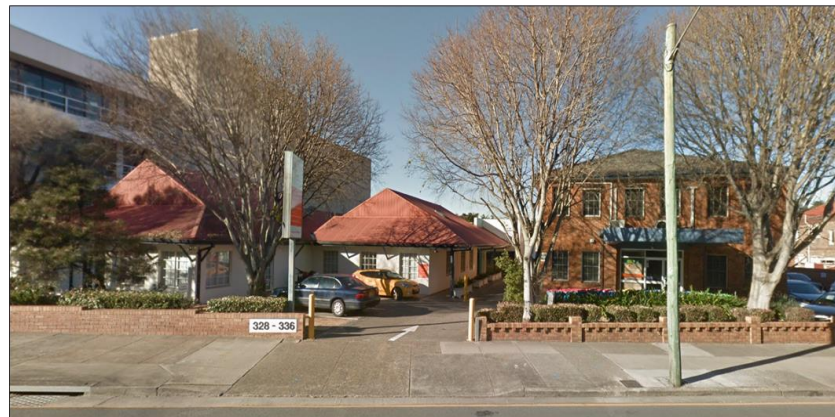
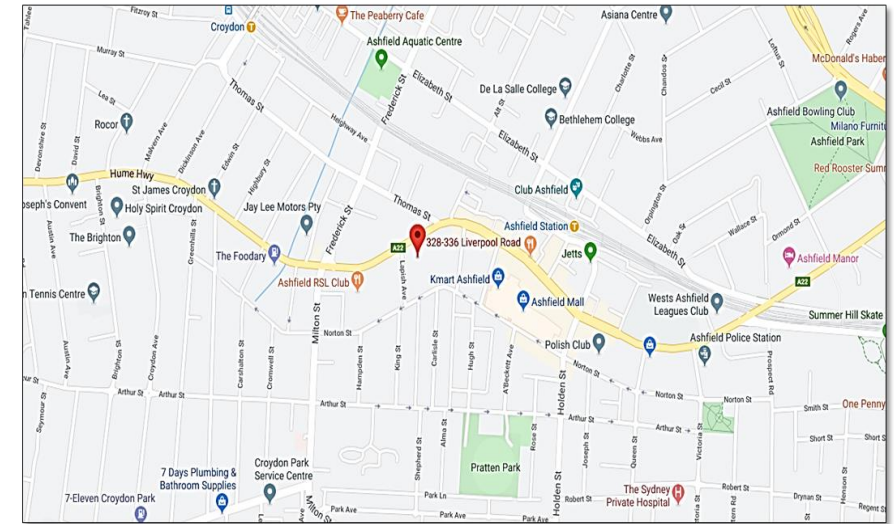

Recent Transaction – Bankstown, NSW

| | |
|-------------------------|--|
| Loan Purpose | Assist purchase of unit block for refurbishment and eventual on sale |
| Loan Amount | \$4,842,000 |
| Loan Term | 24 Months |
| Interest Cover | 0.89 times stand alone and 1.50 times all sources |
| Loan to Valuation Ratio | 65.0% |
| Security | 1 st registered mortgage over the subject property Directors Guarantees GSA over Borrower |

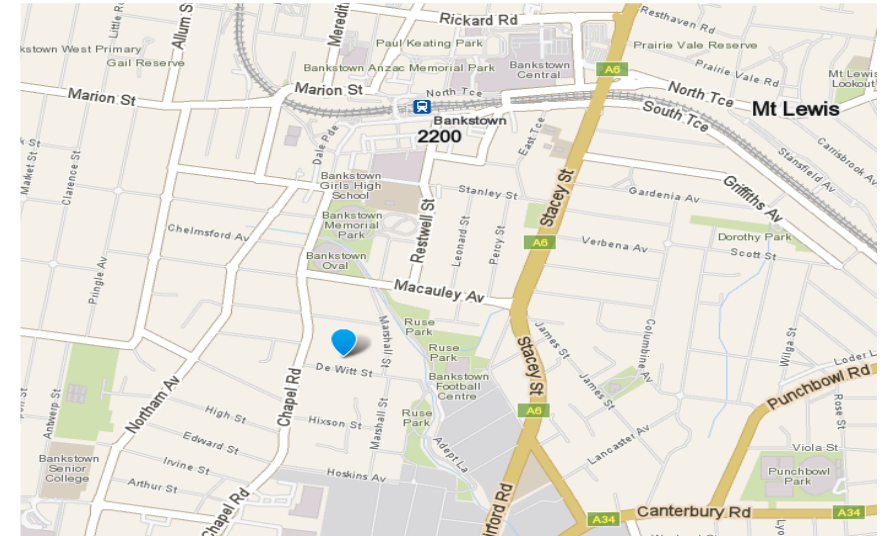

Recent Transaction – Bankstown and Yagoona, NSW

| | |
|-------------------------|---|
| Loan Purpose | Assist refinance of future development site with existing DA in place. |
| Loan Amount | \$6,825,000 |
| Loan Term | 18 Months |
| Interest Cover | Interest capitalised within Loan Amount |
| Loan to Valuation Ratio | 45.0% |
| Security | First Registered Mortgage Director Guarantee General Security Agreement |

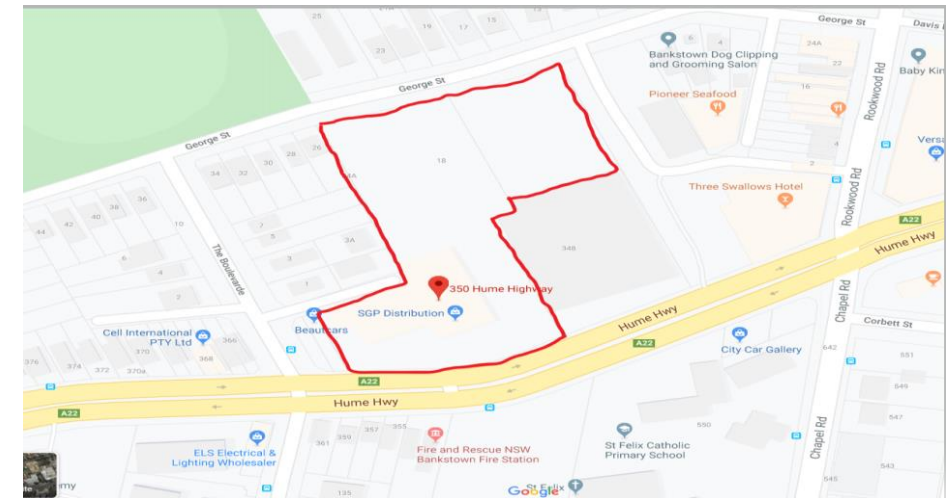

Recent Transaction – Bellevue Hill, NSW

| | |
|-------------------------|---|
| Loan Purpose | Assist purchase of future development site |
| Loan Amount | \$3,150,000 |
| Loan Term | 12 Months |
| Interest Cover | Interest capitalised within Loan Amount |
| Loan to Valuation Ratio | 60.0% |
| Security | First Registered Mortgage Director Guarantee General Security Agreement |

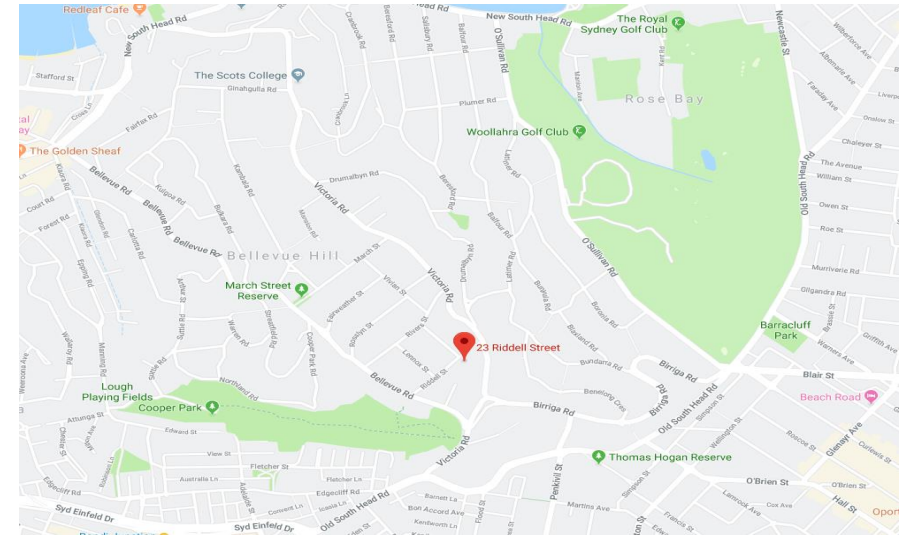

Recent Transaction – Hornsby, NSW

| | |
|-------------------------|---|
| Loan Purpose | Assist purchase of future development site |
| Loan Amount | \$5,035,000 |
| Loan Term | 12 Months |
| Interest Cover | Interest capitalised within Loan Amount |
| Loan to Valuation Ratio | 53.0% |
| Security | First Registered Mortgage Director Guarantee General Security Agreement |

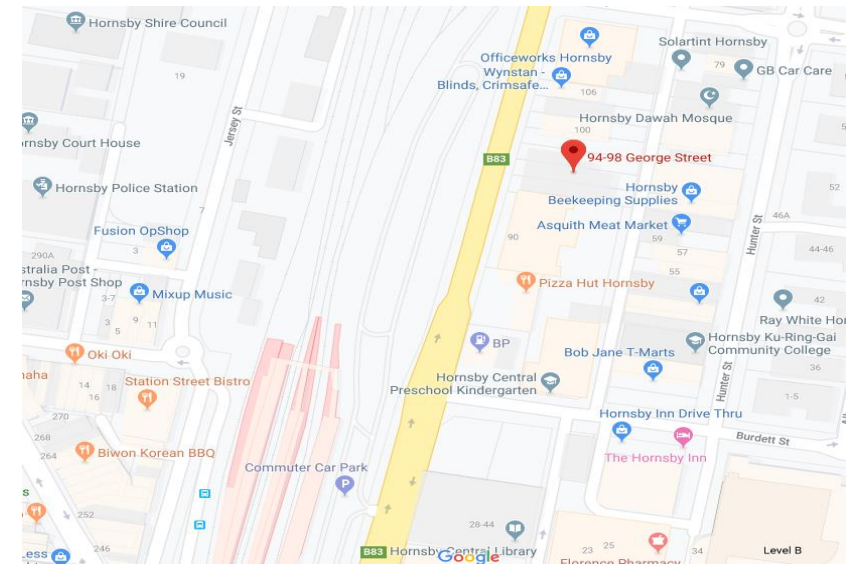

View of subject site from George Street



View of subject site from Hunter Lane

Recent Transaction – Granville, NSW

| | |
|-------------------------|---|
| Loan Purpose | Refinance Industrial Unit- Owner Occupied |
| Loan Amount | \$1,137,000 |
| Loan Term | 12 Months |
| Interest Cover | 14.78 Times, all sources |
| Loan to Valuation Ratio | 65.0% |
| Security | First Registered Mortgage Director Guarantee General Security Agreement |

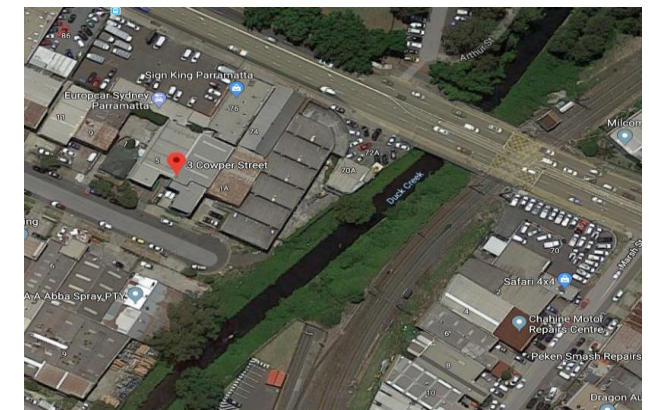
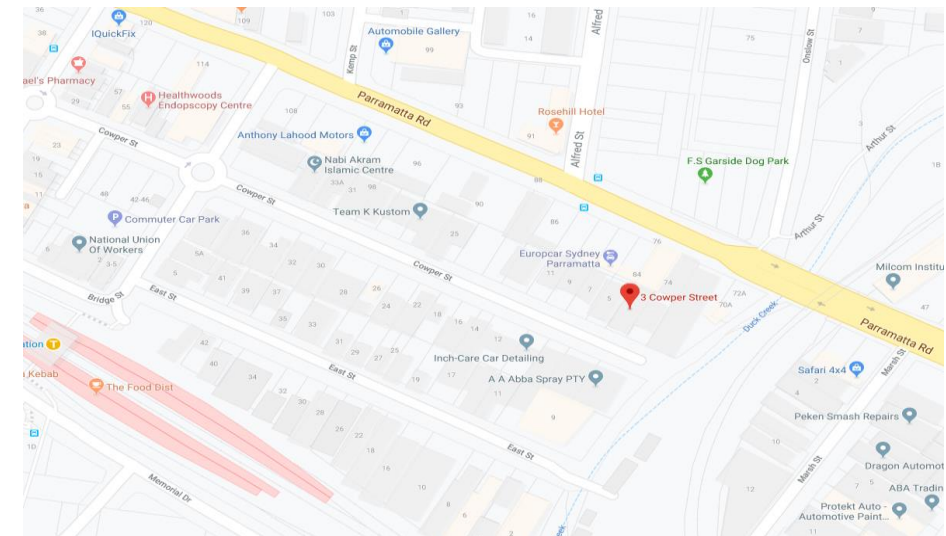

Recent Transaction – Wollri Creek, NSW

| | |
|-------------------------|---|
| Loan Purpose | Assist completion of construction of new boarding house |
| Loan Amount | \$1,450,000 |
| Loan Term | 12 Months |
| Interest Cover | Interest capitalised within Loan Amount |
| Loan to Valuation Ratio | 25.0% |
| Security | First Registered Mortgage Director Guarantee General Security Agreement |

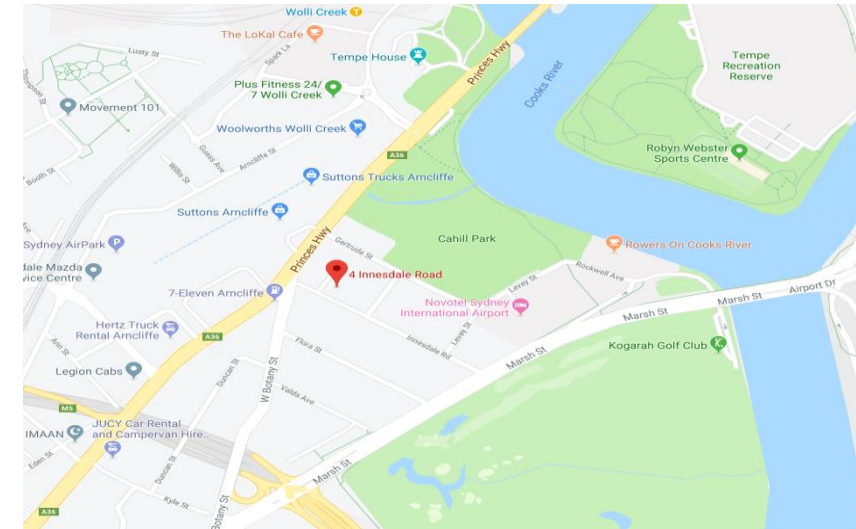

Recent Transaction – Maroochydore, QLD

| | |
|-------------------------|---|
| Loan Purpose | Refinance to repay equity investors |
| Loan Amount | \$1,145,000 |
| Loan Term | 18 Months |
| Interest Cover | Interest capitalised within Loan Amount |
| Loan to Valuation Ratio | 51.0% |
| Security | First Registered Mortgage Director Guarantee General Security Agreement |



Recent Transaction – Albion Park, NSW

| | |
|-------------------------|--|
| Loan Purpose | Purchase of site and completion of residential subdivision of 72 lots |
| Loan Amount | \$12,300,000 |
| Loan Term | 12 Months |
| Interest Cover | Interest capitalised within Loan Amount |
| Loan to Valuation Ratio | Loan To Development Cost Ratio 69% Loan to Value ratio 'as is' and on completion 48% |
| Security | First Registered Mortgage Director Guarantee General Security Agreement Tri partite Deed with Builder |

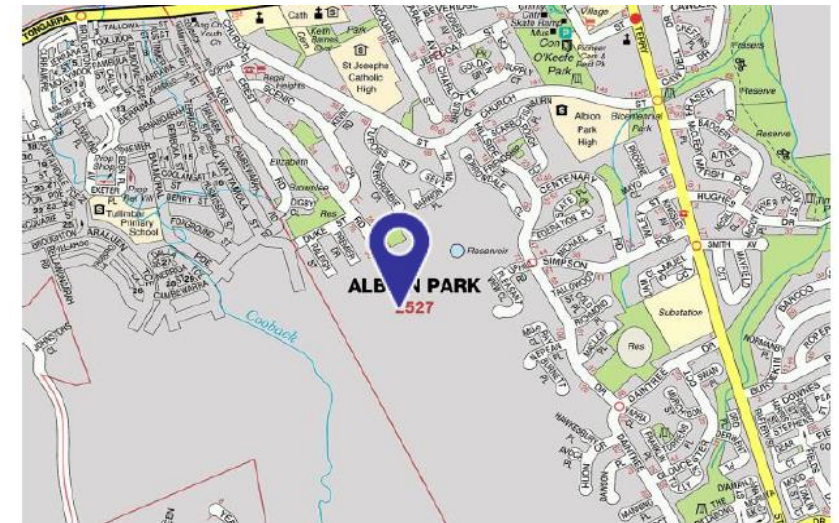

Recent Transaction – Dapto, NSW

| | |
|-------------------------|--|
| Loan Purpose | Fund subdivision and bulk earthworks costs |
| Loan Amount | \$9,030,000 |
| Loan Term | 15 Months |
| Interest Cover | Interest capitalised within Loan Amount |
| Loan to Valuation Ratio | Loan To Development Cost Ratio 50.0% Loan to Value ratio 'as is' and on completion 40.0% |
| Security | First Registered Mortgage Director Guarantee General Security Agreement Tri partite Deed with Builder |

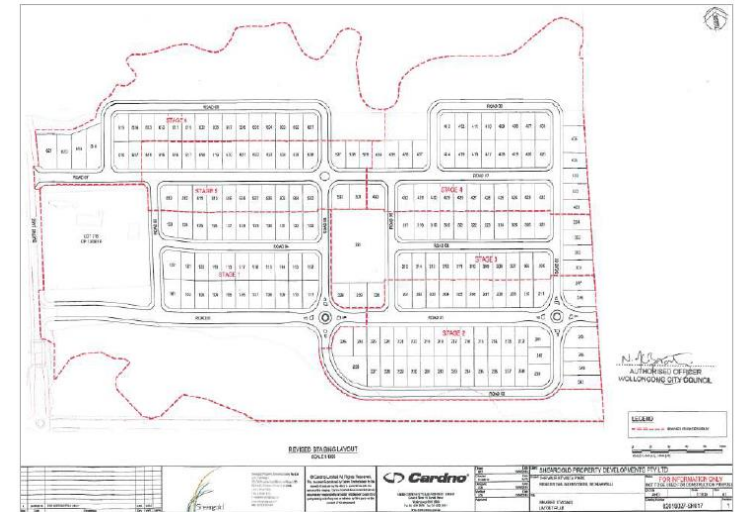

Recent Transaction – Wollongong, NSW

| | |
|-------------------------|--|
| Loan Purpose | Equity Release against residual units to inject to construction project |
| Loan Amount | \$2,132,000 |
| Loan Term | 12 Months |
| Interest Cover | Interest capitalised within Loan Amount 1.25 times, with all property outgoings prepaid |
| Loan to Valuation Ratio | 55.0% |
| Security | First Registered Mortgage Director Guarantee General Security Agreement |

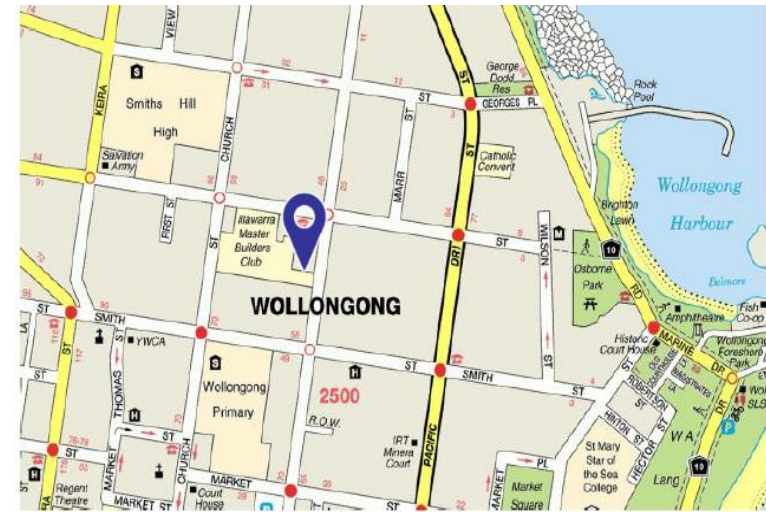

Recent Transaction – Northmead, NSW

| | |
|-------------------------|--|
| Loan Purpose | Syndicate Participation with Security Trustee |
| Loan Amount | \$10,000,000 |
| Loan Term | 24 Months |
| Interest Cover | 1.67 times |
| Loan to Valuation Ratio | 58.0% |
| Security | First Ranking Priority over Security Director Guarantee General Security Agreement |

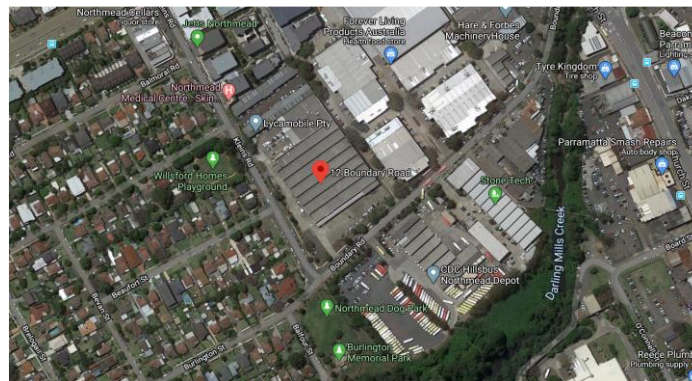

Recent Transaction – Parramatta, NSW

| | |
|-------------------------|---|
| Loan Purpose | Refinance of Vendor Loan |
| Loan Amount | \$30,000,000 |
| Loan Term | 18 Months |
| Interest Cover | Interest and Property Holding costs capitalised within Loan Amount |
| Loan to Valuation Ratio | 50.0% |
| Security | First Registered Mortgage Director Guarantee General Security Agreement |

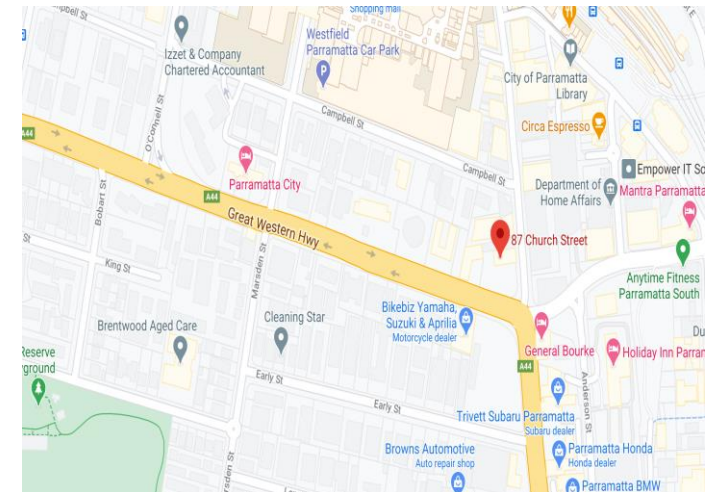

Recent Transaction – Sunshine Coast Residential Subdivision

| | |
|-------------------------|---|
| Loan Purpose | Residual stock loan to provide equity release for construction project |
| Loan Amount | \$2,845,000 |
| Loan Term | 12 months |
| Interest Cover | Interest capitalised within Loan Amount |
| Loan to Valuation Ratio | 55.0% |
| Security | First Registered Mortgage Director Guarantee General Security Agreement |



Recent Transaction – Completed Residential Subdivision - Kenmore, QLD

| | |
|-------------------------|--|
| Loan Purpose | Residual stock facility to assist with refinance of existing construction lender |
| Loan Amount | \$1,450,000 |
| Loan Term | 12 Months |
| Interest Cover | Interest capitalised within Loan Amount |
| Loan to Valuation Ratio | 55.0% |
| Security | First Registered Mortgage Director Guarantee General Security Agreement |



Recent Transaction – Completed Residential Subdivision – Port Macquarie, NSW

| | |
|-------------------------|---|
| Loan Purpose | Refinance of existing construction lenders and equity release for next project site acquisition |
| Loan Amount | \$11,350,000.00 |
| Loan Term | 12 Months |
| Interest Cover | Retained interest for loan term, 10 pre-sales in place |
| Loan to Valuation Ratio | 64.0% |
| Security | First Registered Mortgage Director Guarantee General Security Agreement |

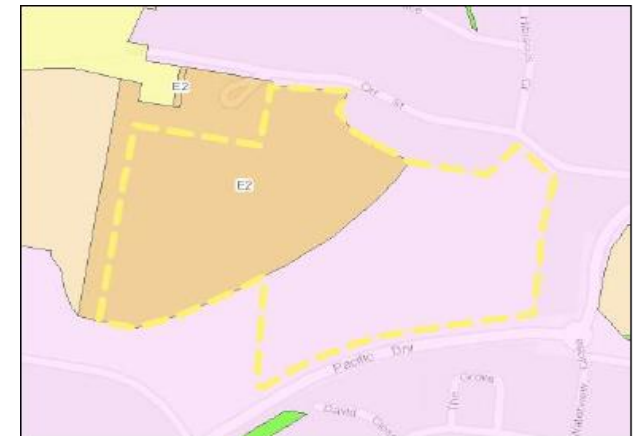

Recent Transaction – Residual Stock Transaction- Kew, VIC

| | |
|-------------------------|--|
| Loan Purpose | Refinance of existing construction lender and release equity for another development project. |
| Loan Amount | \$5,395,000.00 |
| Loan Term | 12 Months |
| Interest Cover | Interest capitalised within Loan Amount |
| Loan to Valuation Ratio | 65.0% |
| Security | First Registered Mortgage Director Guarantee General Security Agreement – Borrower General Security Agreement - Guarantor |



Recent Transaction – Development Site Loan – Wantirna, VIC

| | |
|-------------------------|--|
| Loan Purpose | Assist with refinance of existing site funding to allow progression of planning strategy |
| Loan Amount | \$8,624,000.00 |
| Loan Term | 18 Months |
| Interest Cover | Interest capitalised within Loan Amount |
| Loan to Valuation Ratio | 56.0% |
| Security | First Registered Mortgage Director Guarantee General Security Agreement – Borrower General Security Agreement - Guarantor |



Recent Transaction – Development Site Refinance- Southport, QLD

| | |
|-------------------------|---|
| Loan Purpose | Assist with refinance of existing development site funding |
| Loan Amount | \$4,750,000.00 |
| Loan Term | 12 Months |
| Interest Cover | Interest capitalised within Loan Amount |
| Loan to Valuation Ratio | 35.0% |
| Security | First Registered Mortgage Director Guarantee General Security Agreement |



Recent Transaction – Development Site Loan, Willoughby, NSW

| | |
|-------------------------|---|
| Loan Purpose | Assist purchase of 2 residential houses for future redevelopment |
| Loan Amount | \$3,240,000.00 |
| Loan Term | 12 Months |
| Interest Cover | Interest capitalised within Loan Amount |
| Loan to Valuation Ratio | 60.0% |
| Security | First Registered Mortgage Director Guarantee General Security Agreement |

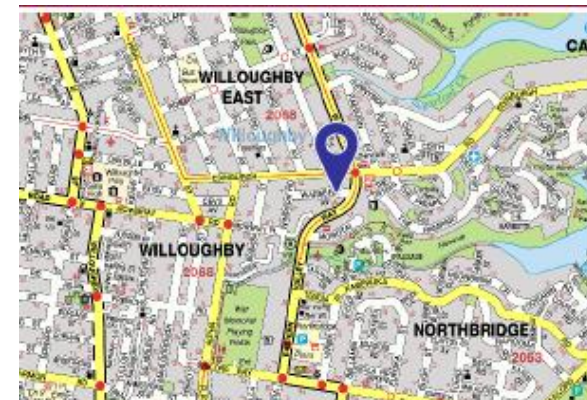

Recent Transaction – Construction Loan, West Dapto, NSW

| | |
|-------------------------|--|
| Loan Purpose | Assist with a construction of nine residential properties for existing Borrower in a multi-stage development. Six pre-sales in place |
| Loan Amount | \$4,123,000.00 |
| Loan Term | 12 Months |
| Interest Cover | Interest capitalised within Loan Amount |
| Loan to Valuation Ratio | 60.0% |
| Security | First Registered Mortgage Director Guarantee General Security Agreement – Borrower General Security Agreement - Guarantor |



Recent Transaction – Residual Stock Loan, Malvern, VIC

| | |
|-------------------------|---|
| Loan Purpose | Residual stock facility secured by six (6) lots to assist with refinance of construction lender |
| Loan Amount | \$3,058,000.00 |
| Loan Term | 6 Months |
| Interest Cover | Interest capitalised within Loan Amount |
| Loan to Valuation Ratio | 65.0% |
| Security | First Registered Mortgage Director Guarantee General Security Agreement |

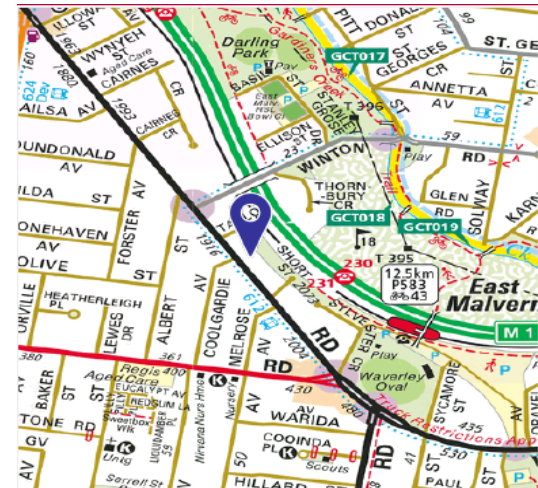

Recent Transaction – Construction Loan, Sutherland, NSW

| | |
|-------------------------|---|
| Loan Purpose | Construction facility to assist with refinance of existing c lender and construction funding to finish 24unit residential project for existing Borrower |
| Loan Amount | \$11,800,000.00 |
| Loan Term | 12 Months |
| Interest Cover | Interest Capitalised within construction facility |
| Loan to Valuation Ratio | 62.0% |
| Security | First Registered Mortgage Director Guarantee General Security Agreement |



Further information

For further information please contact:

Michael Vella

Chief Executive Officer

Phone: +61 2 9954 2209

Mobile: +61 408 210 250

Michael.vella@schrodersrf.com

Allen Tulich

General Manager Credit and Lending

Phone: +61 9954 2204

Mobile: +61 402 285 676

Allen.tulich@schrodersrf.com

Malcolm Vaughan

Manager Originations and Business Development

Phone: +61 9954 2206

Mobile: +61 488 663 255

Malcolm.vaughan@schrodersrf.com

Shane Craig

Portfolio Manager - Queensland

Phone: +61 2 9954 2211

Mobile: +61 417 499 563

Shane.craig@schrodersrf.com

PO Box 12001

George Street

Brisbane QLD 4003

Andrew Papas

Manager Originations and Business Development

Phone: +61 2 9954 2222

Mobile: +61 490 833 348

Andrew.papas@schrodersrf.com

PO Box 5337

Mordialloc VIC 3195

Level 9, 60 Castlereagh St
Sydney NSW 2000

Important Notice

Schroders RF Limited ABN 54 089 265 270 AFS Licence 238546 (**Schroders RF**) as responsible entity for the Schroders RF Select Credit Fund ARSN 090 994 326 (Schroders RF **Fund**) has prepared this presentation for discussion purposes only. It contains general information and does not take into account the investment objectives, financial situation, tax position or particular needs of any particular person or corporation.

This presentation does not represent an offer to sell, or a solicitation of any offer to invest in any product or fund. Before acting on this presentation you should obtain and carefully consider the Product Disclosure Statement (**PDS**) for the Schroders RF Fund. An electronic copy of the PDS may be accessed at www.schrodersrf.com.

Prior to acting upon any information contained in this presentation, recipients should seek professional advice, including legal, regulatory, tax, investment, financial and accounting advice and should carry out their own due diligence, in making their own independent assessment of, and investigation into the risks associated with and the appropriateness of the investments, strategies or information contained in this presentation.

This presentation and any information, which may be proprietary in nature, disclosed in it is intended for the exclusive use of the recipients and is provided on the express understanding that the information in this presentation will be treated as strictly confidential and may not be reproduced, copied or distributed in any way without the prior consent of Schroders RF.

While Schroders RF tries to ensure that the content of this information sheet is accurate, adequate or complete, it does not represent or warrant its accuracy, adequacy or completeness. Schroders RF is not responsible for any loss suffered as a result of or in relation to the use of this information sheet and, to the extent permitted by law, Schroders RF excludes any liability, including any liability for negligence, for any loss, including indirect or consequential damages arising from or in relation to the use of this information sheet.

By accepting a copy of this presentation, you agree to be bound by the limitations set out in this disclaimer.